

STICK CHAIR BASICS

---

# INTRO TO MAKING STICK CHAIRS



# BEAUTY AND SIMPLICITY

Dylan van Graan



# KEY CONCEPTS

---

- GEOMETRY  
CONSTRUCTION  
PARTS  
DESIGN

THE HARDEST PART?!

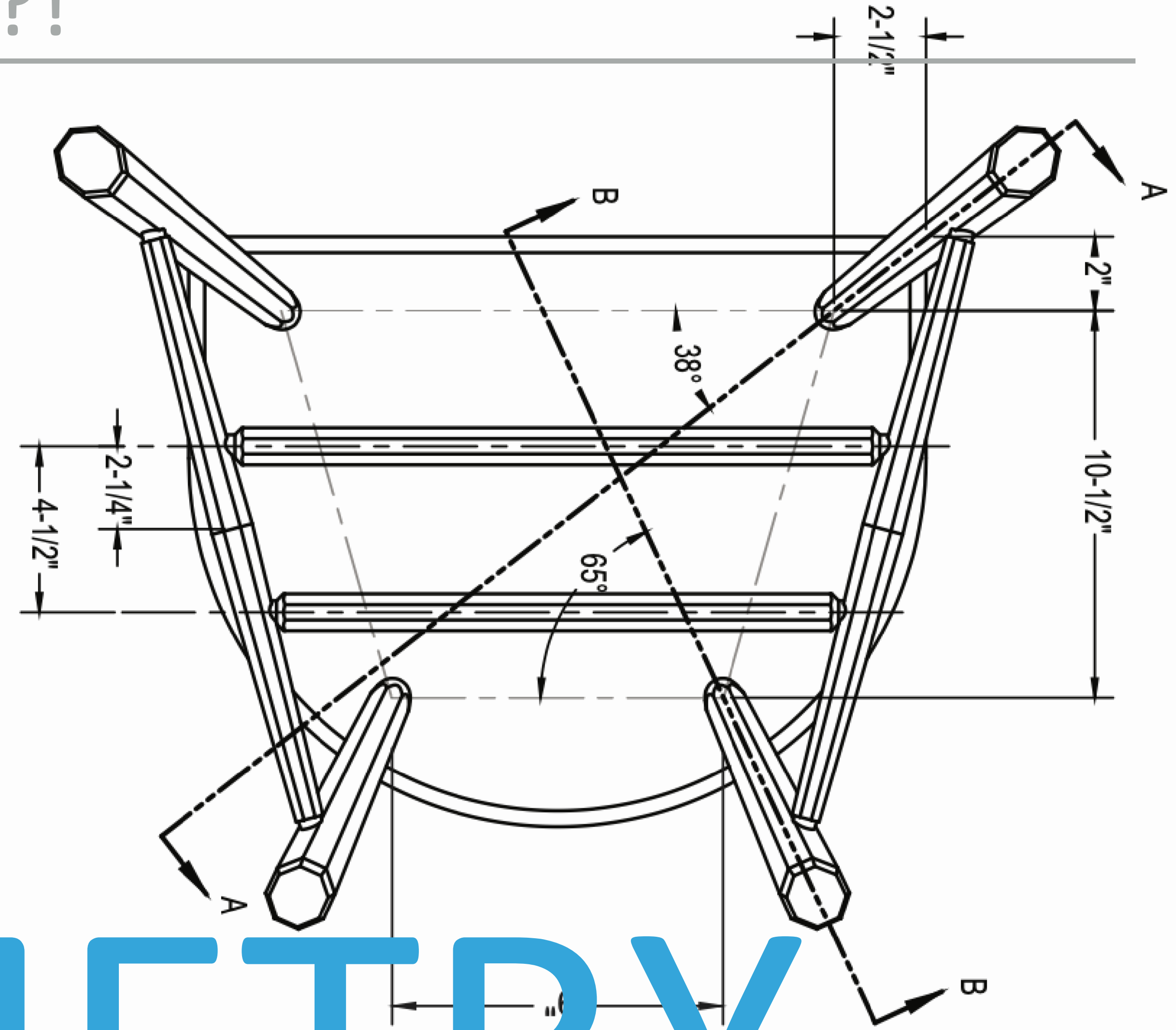
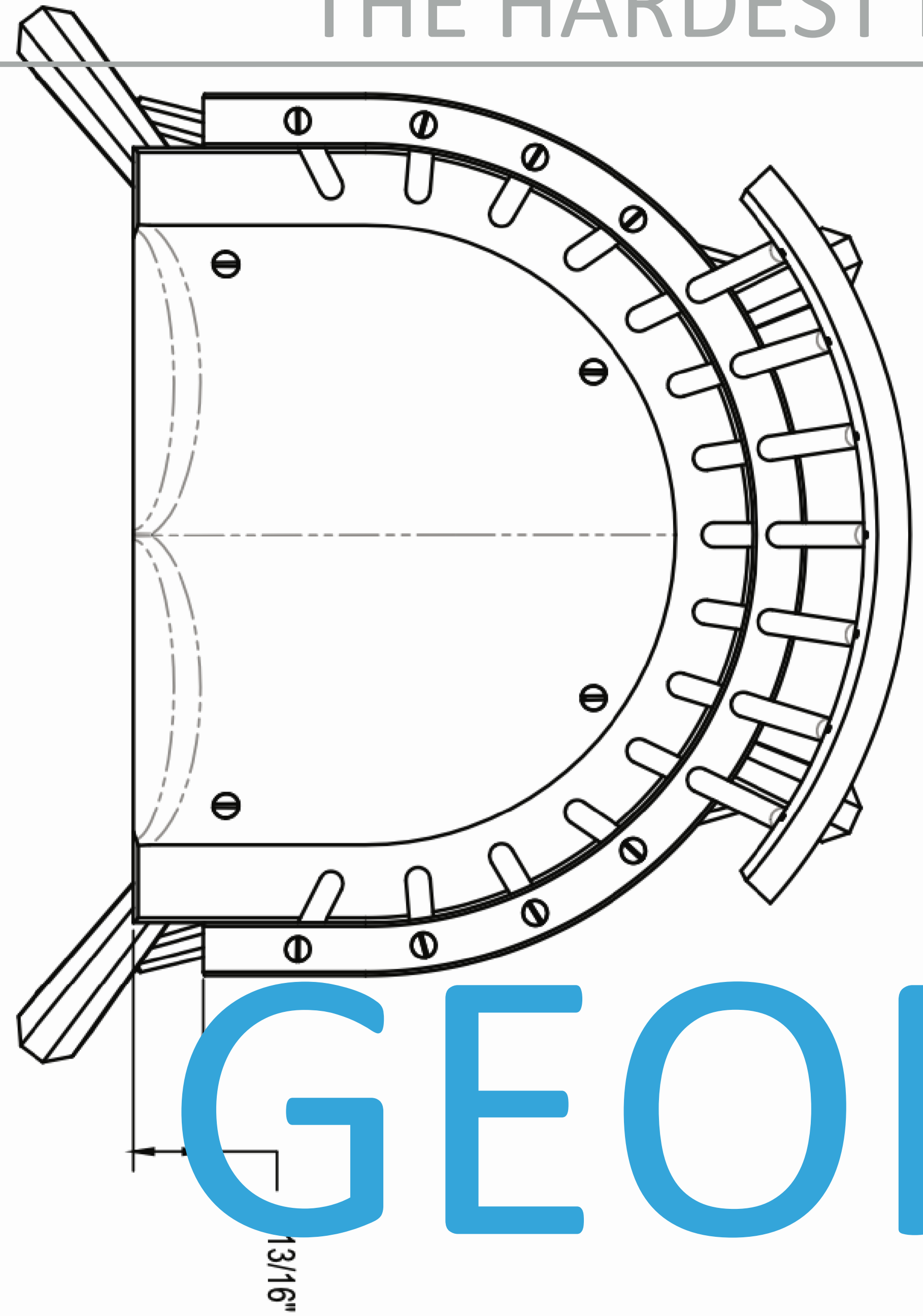

G E O M E T R Y

# SIGHT LINES AND STUFF.....

- ▶ Rake
- ▶ Splay
- ▶ Sightline
- ▶ Resultant Angle
- ▶ 2 Ways To a Sightline
- ▶ What Is The Resultant Angle?

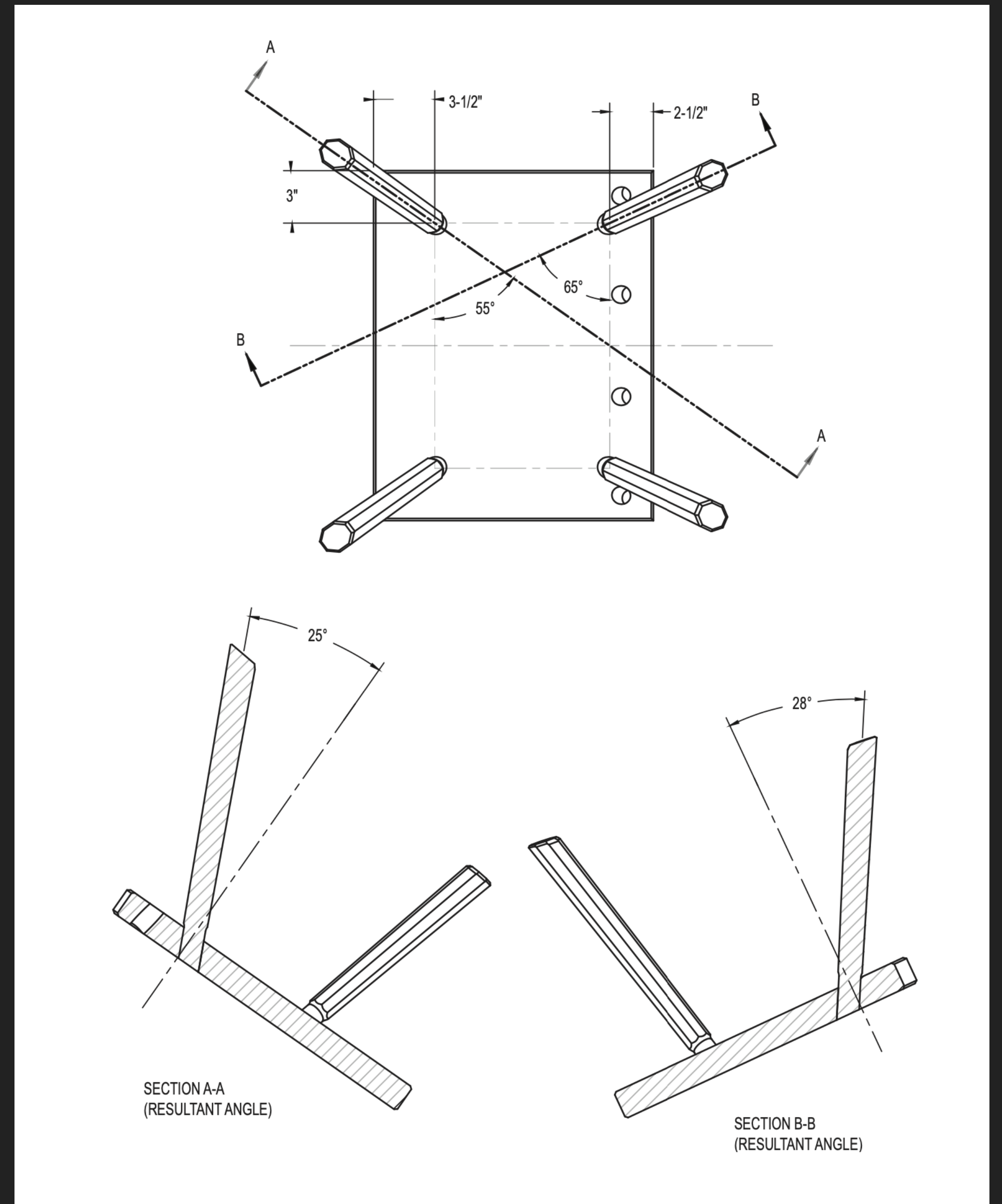

MAYBE?

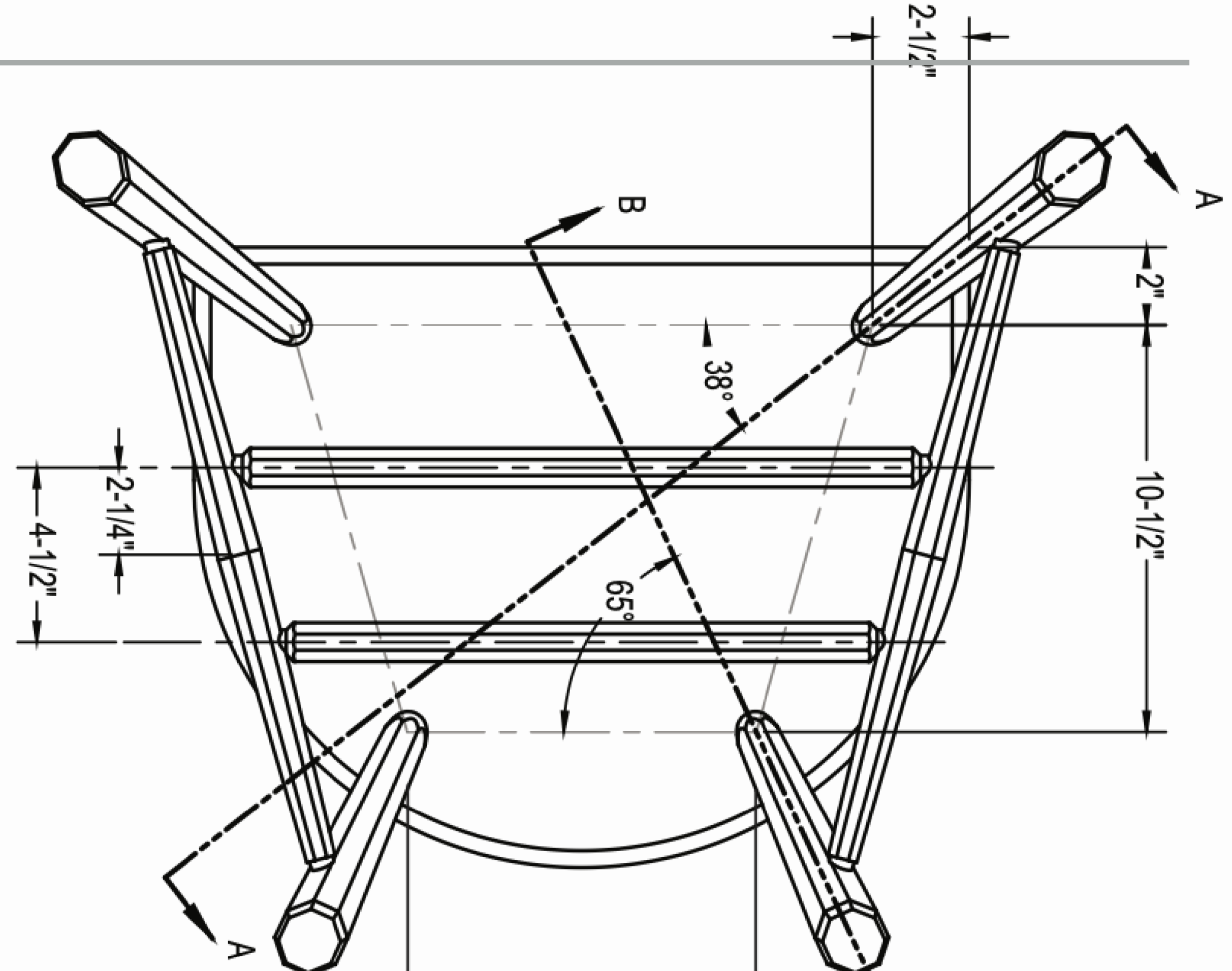
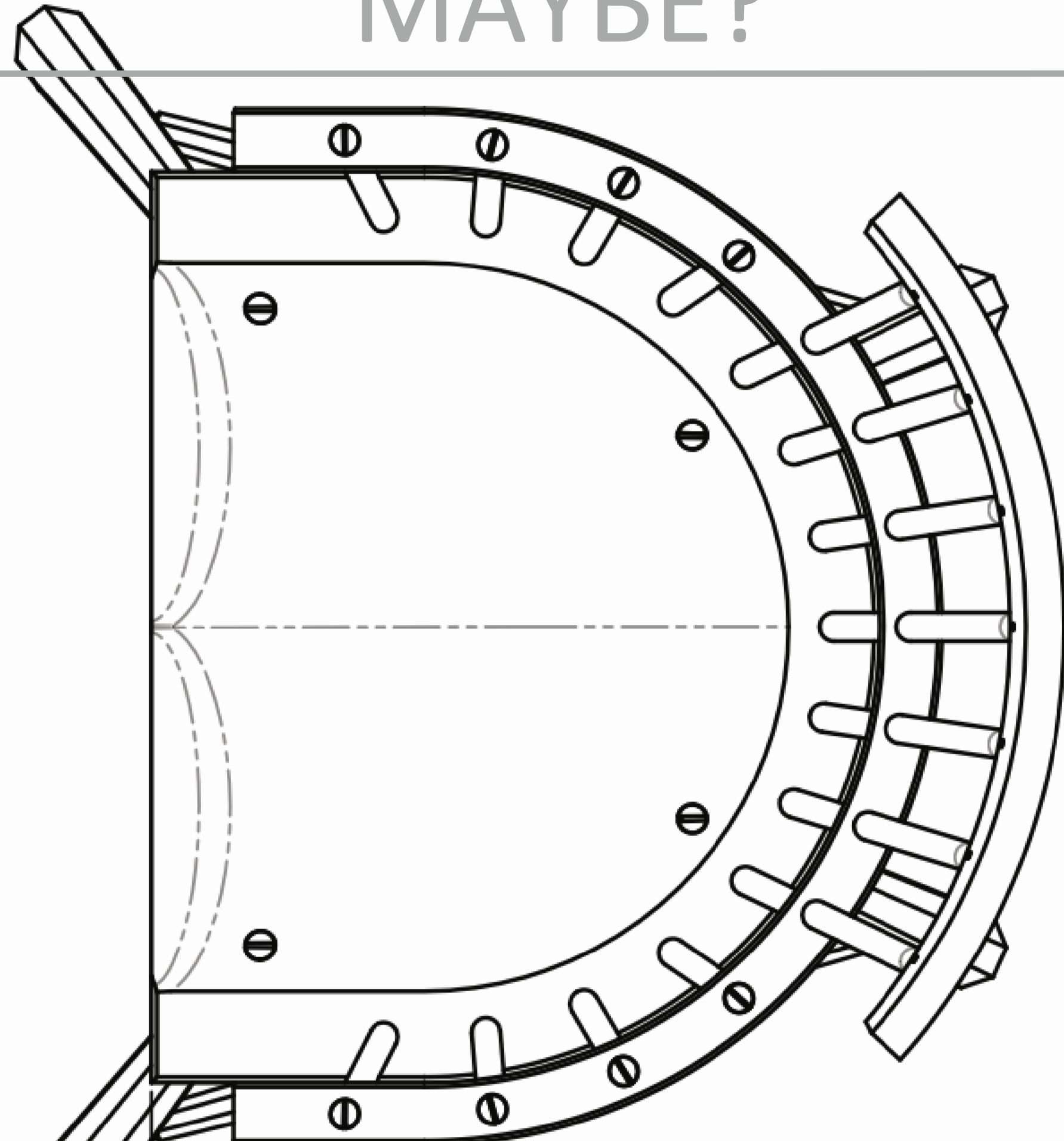

CONSTRUCTION

$1\frac{13}{16}$ "

$6$ "

# TO TAPER OR NOT TO TAPER.....

- ▶ Wedged Mortise & Tenon
- ▶ Tapered
- ▶ Parallel
- ▶ Making Tenons - 3 Ways
- ▶ Drilling Mortises - We all need help!

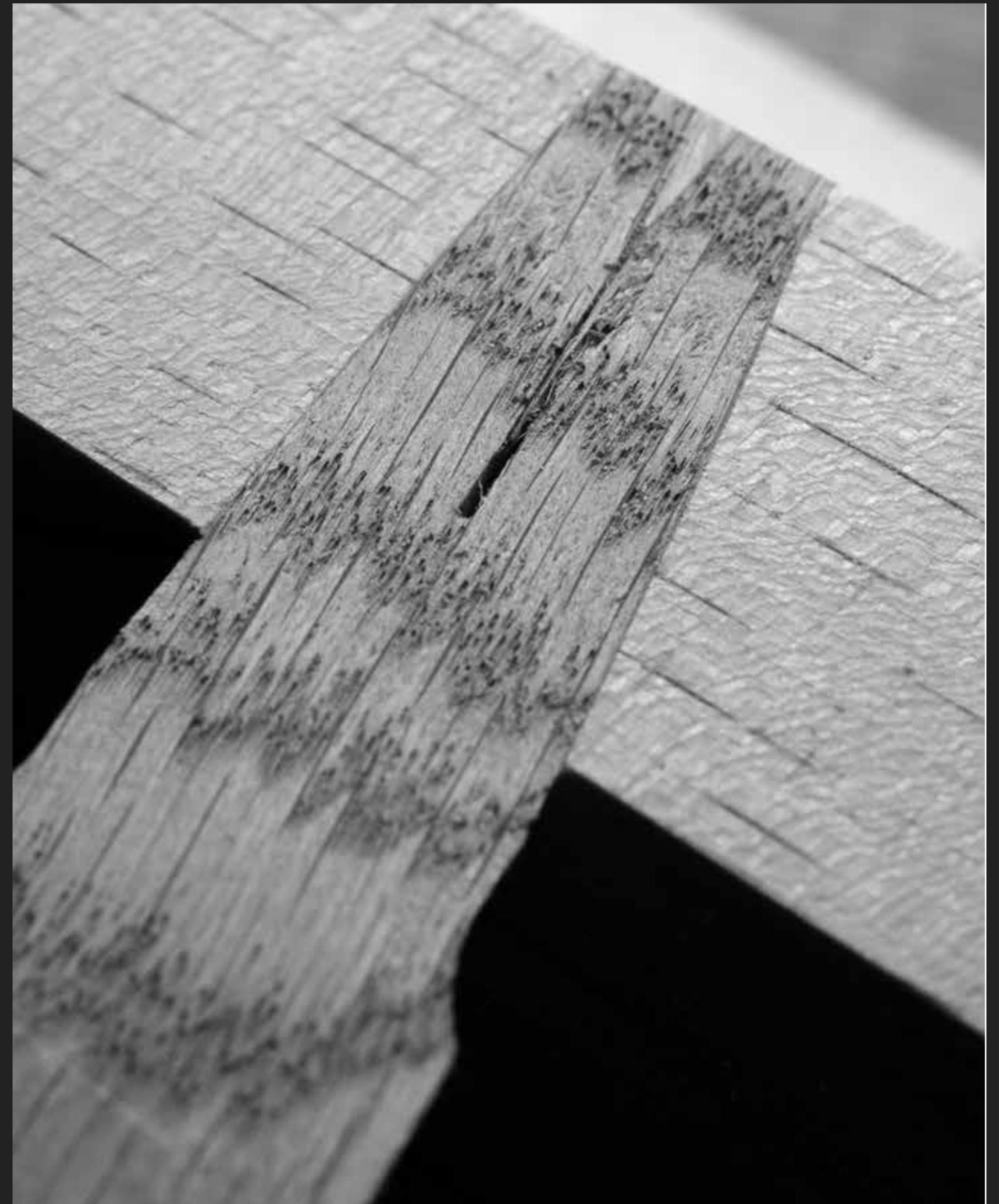

MOST WORK BY FAR!!!

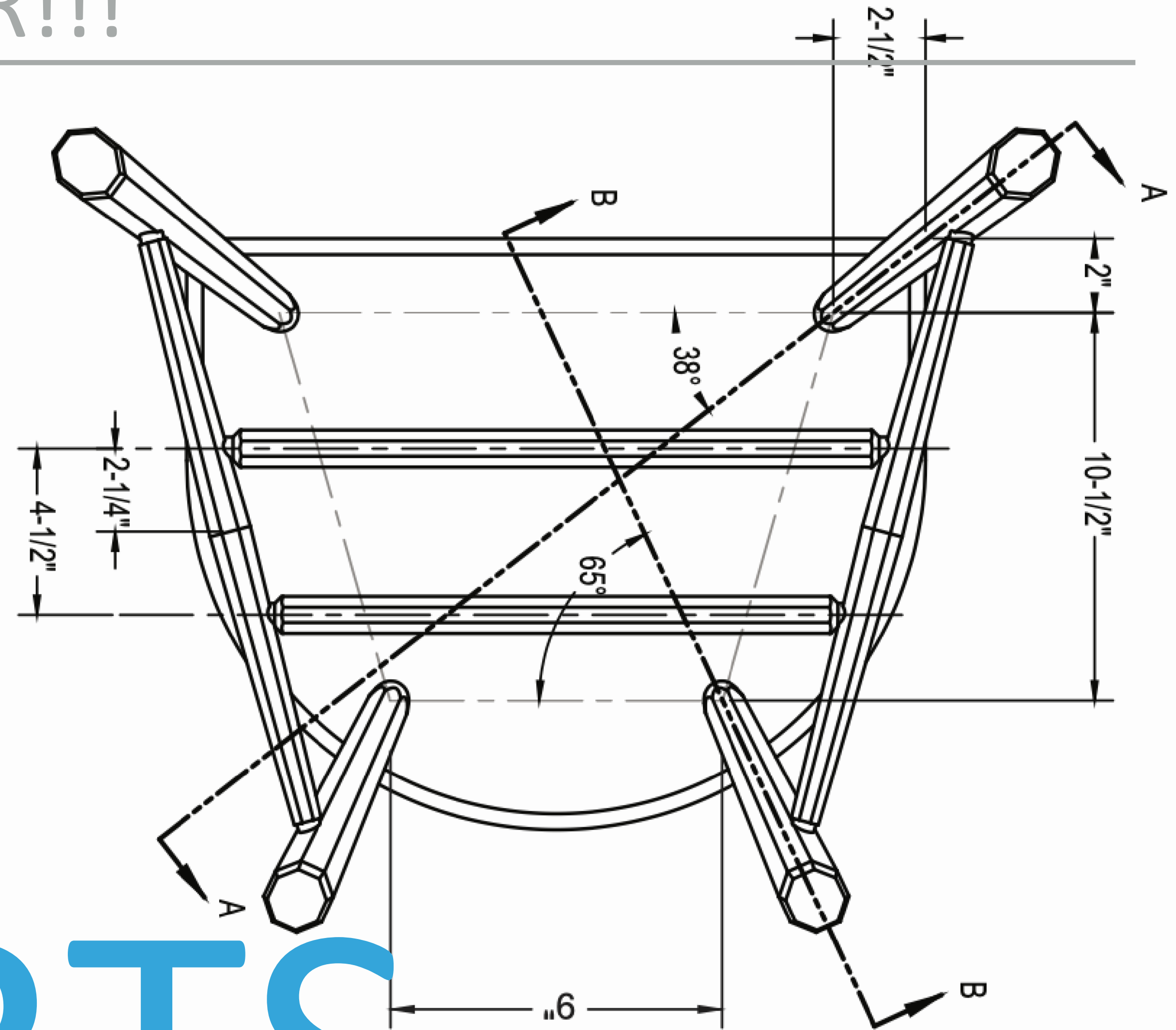
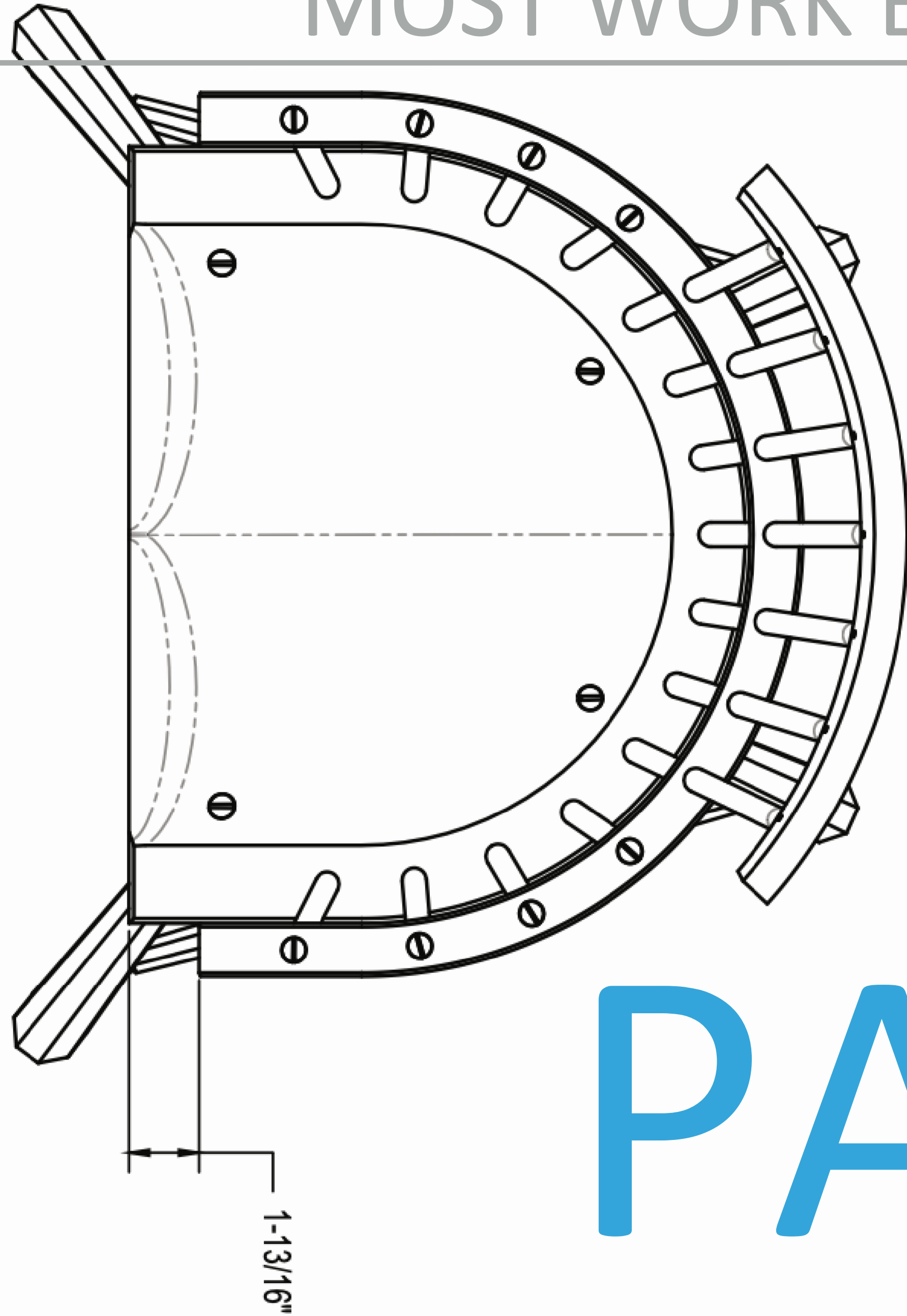

PARTS



## HAND OR MACHINE BUT MAINLY BY HAND.....

- ▶ Octagonalise, Ogtagonalise, Ogtagonalise!
- ▶ 3 Ways
- ▶ How do I go about it and jigs

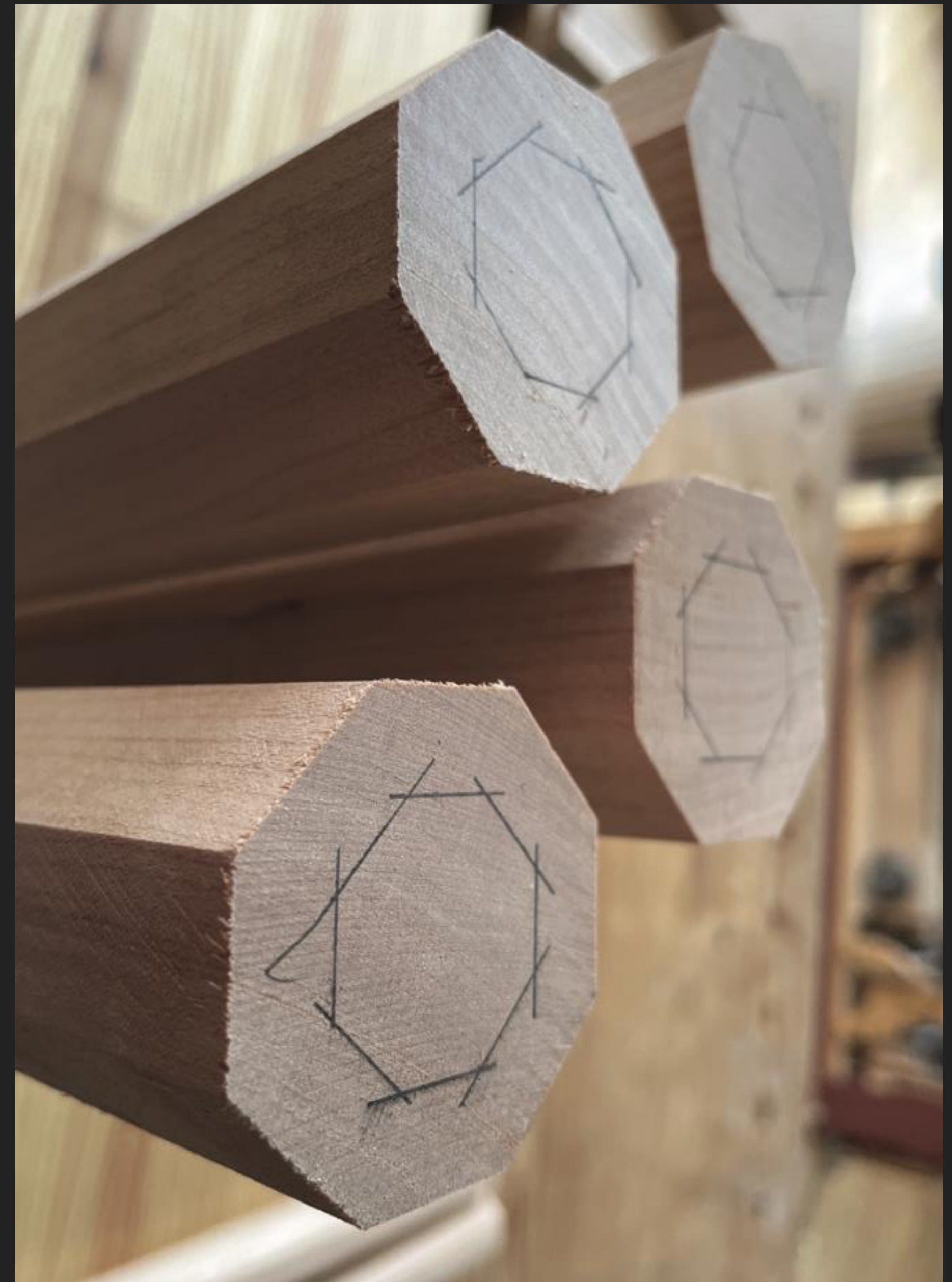

LET SOMEONE ELSE DO IT.....

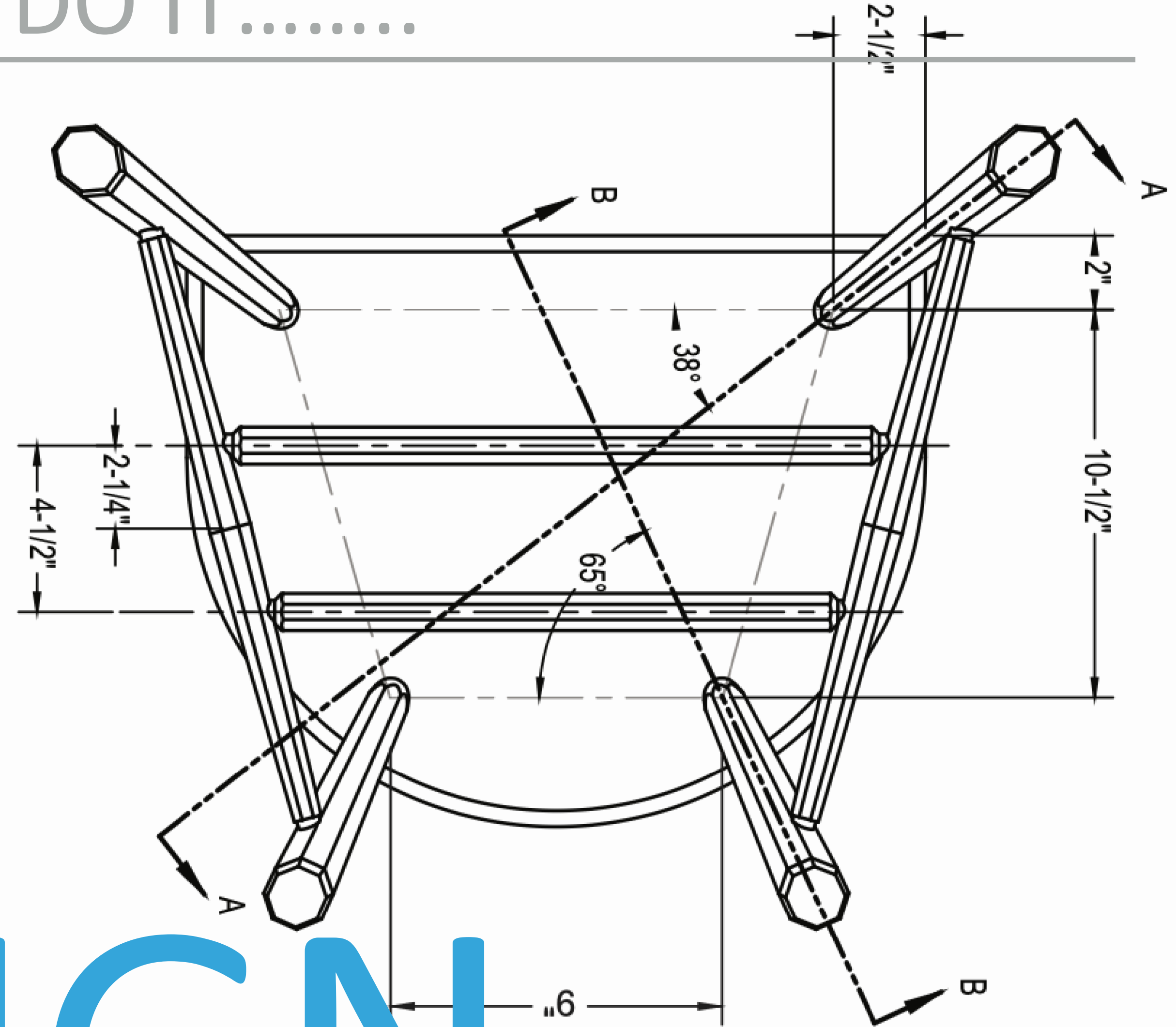
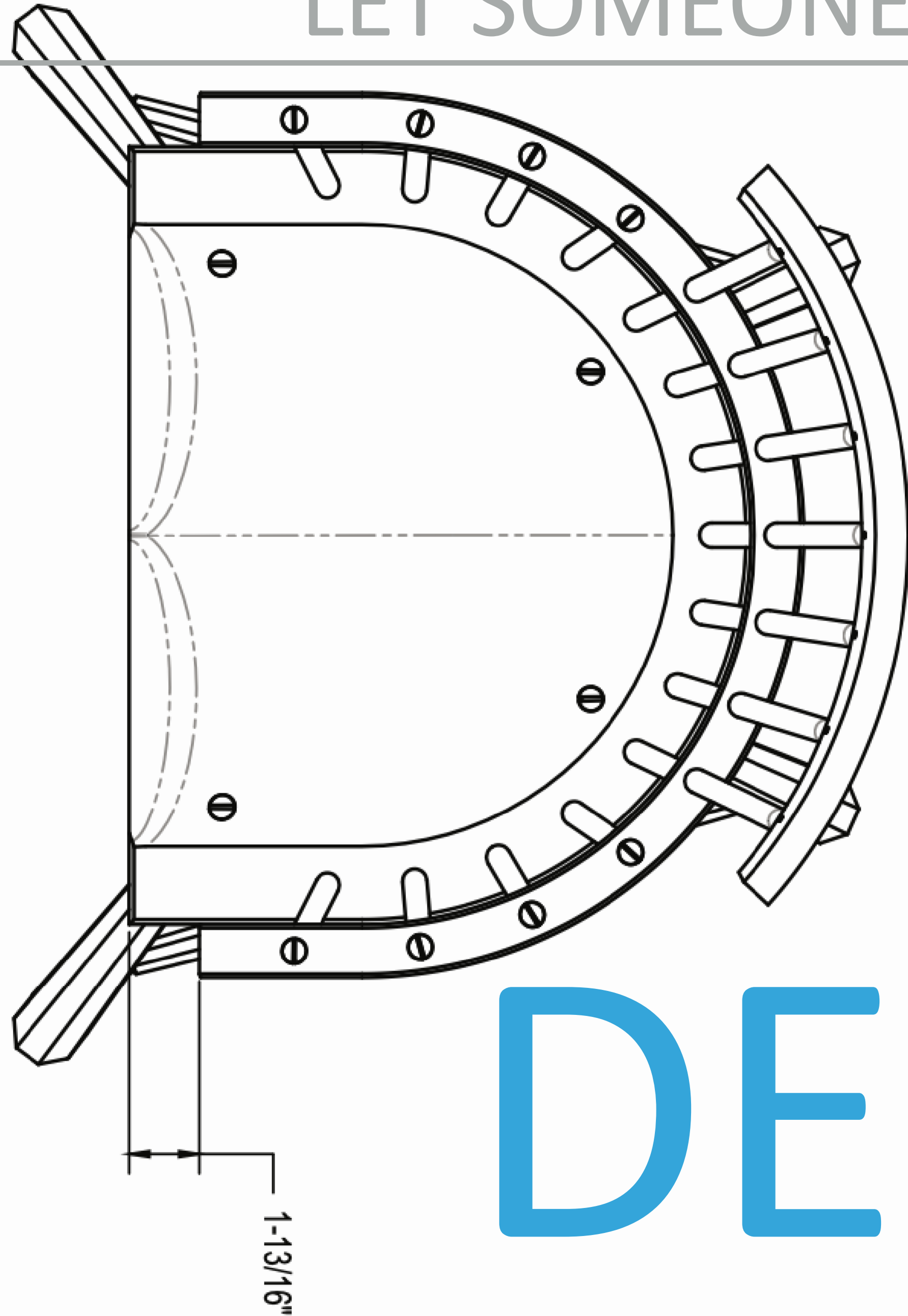

DESIGN

# PLENTY STRONG.....

- ▶ 2 Reasons For Needing an Undercarriage
- ▶ Other parts
- ▶ Bending



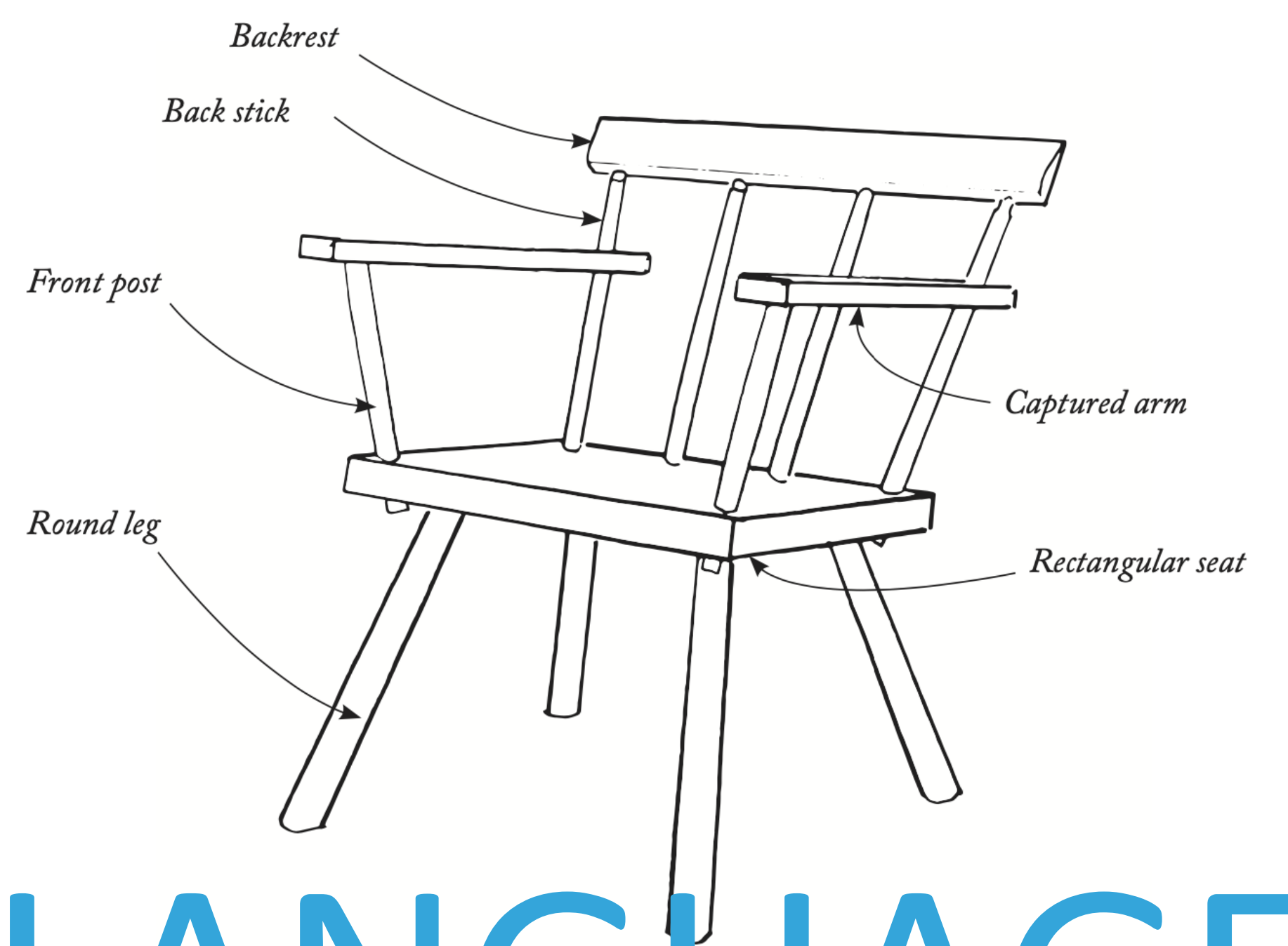
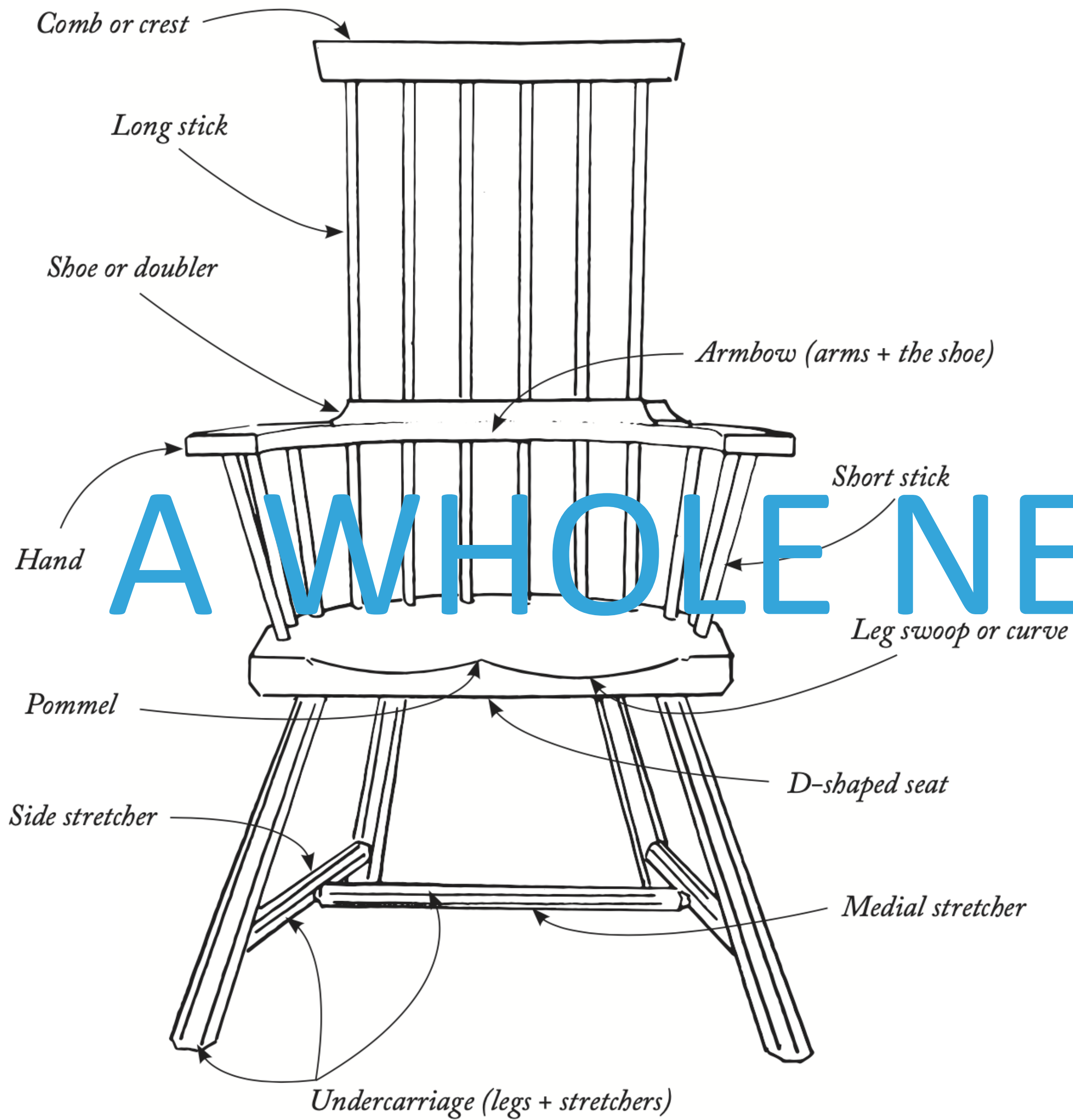

# A WHOLE NEW LANGUAGE

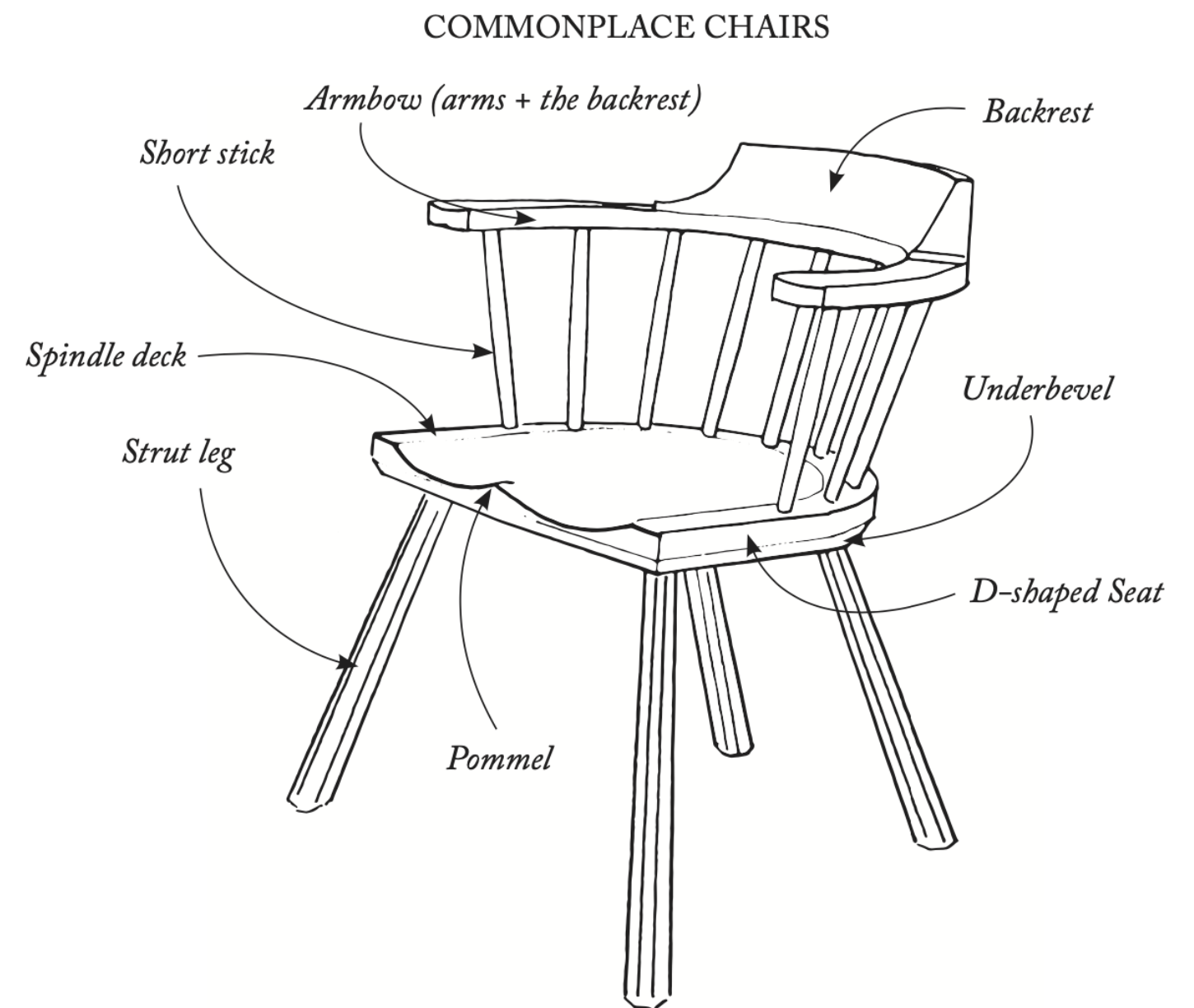

## WANT TO KNOW MORE?

- ▶ [PlyCreations](#)
- ▶ [Chair Jigs Article](#)
- ▶ [Lost Art Press](#)
- ▶ [The Stick Chair Book](#)
- ▶ [Peter Galbert Chairmaker](#)
- ▶ [Peter Galbert YouTube](#)

A close-up photograph of two light-colored wooden chopsticks. The chopsticks are positioned diagonally across the frame, with the foreground chopstick in sharp focus and the background one blurred. The background is a solid, deep blue color. The chopsticks have a natural wood grain and a slightly rough, unfinished appearance at the ends.

THANK YOU!!

QA